

NOTES:
1. SEE SHEET 1 FOR GENERAL NOTES.

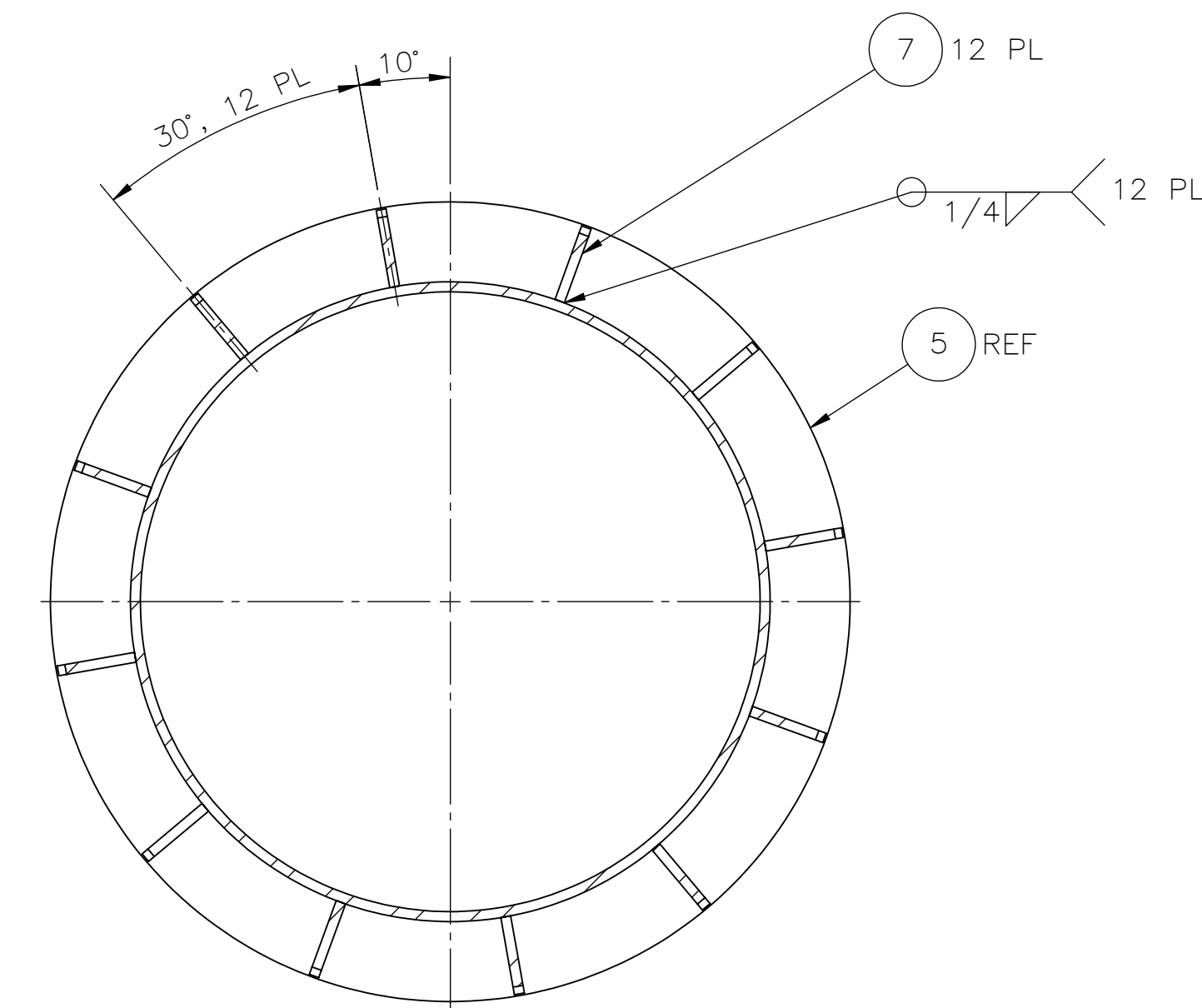

SECTION B-B
SCALE: 1"=1'-0"

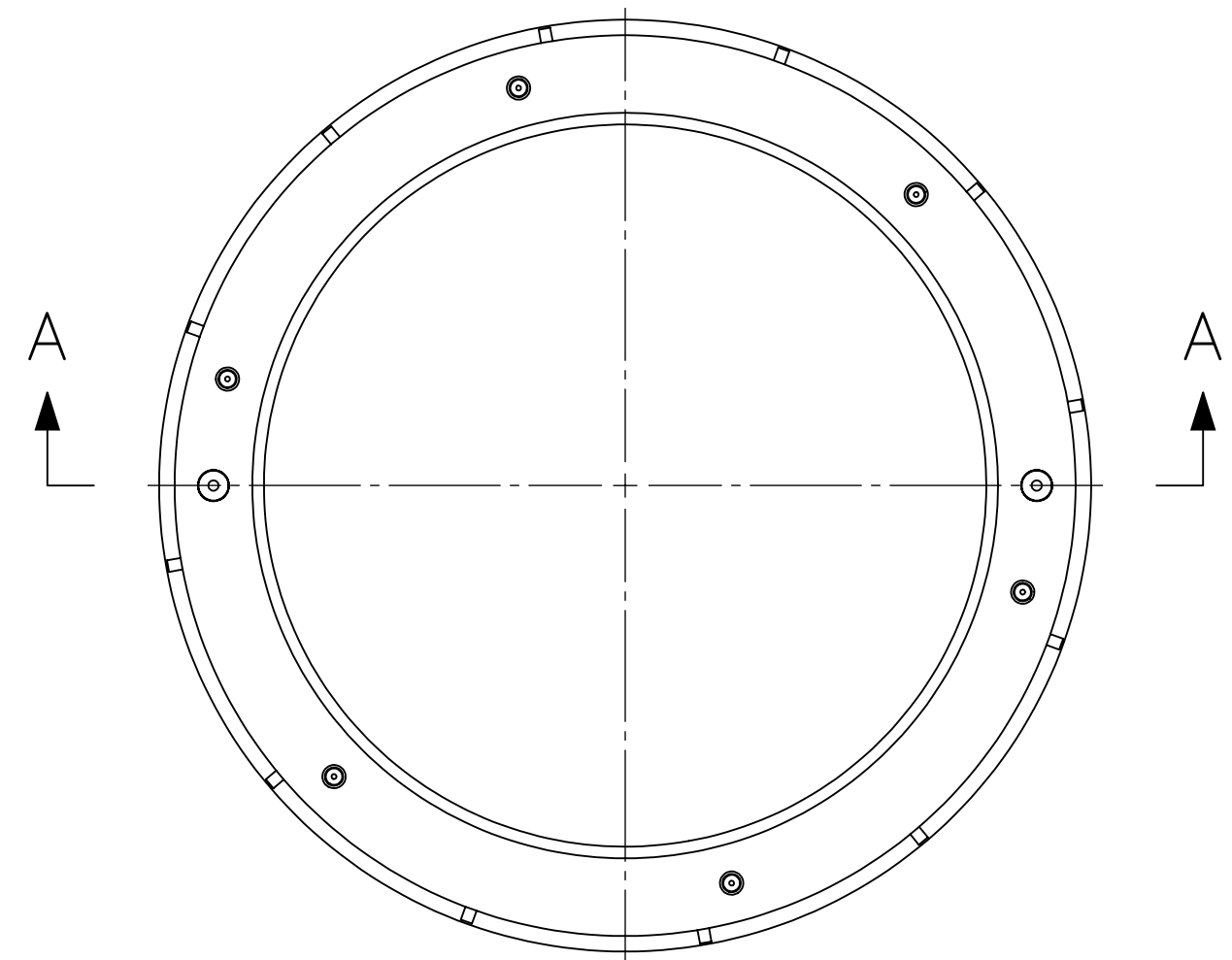
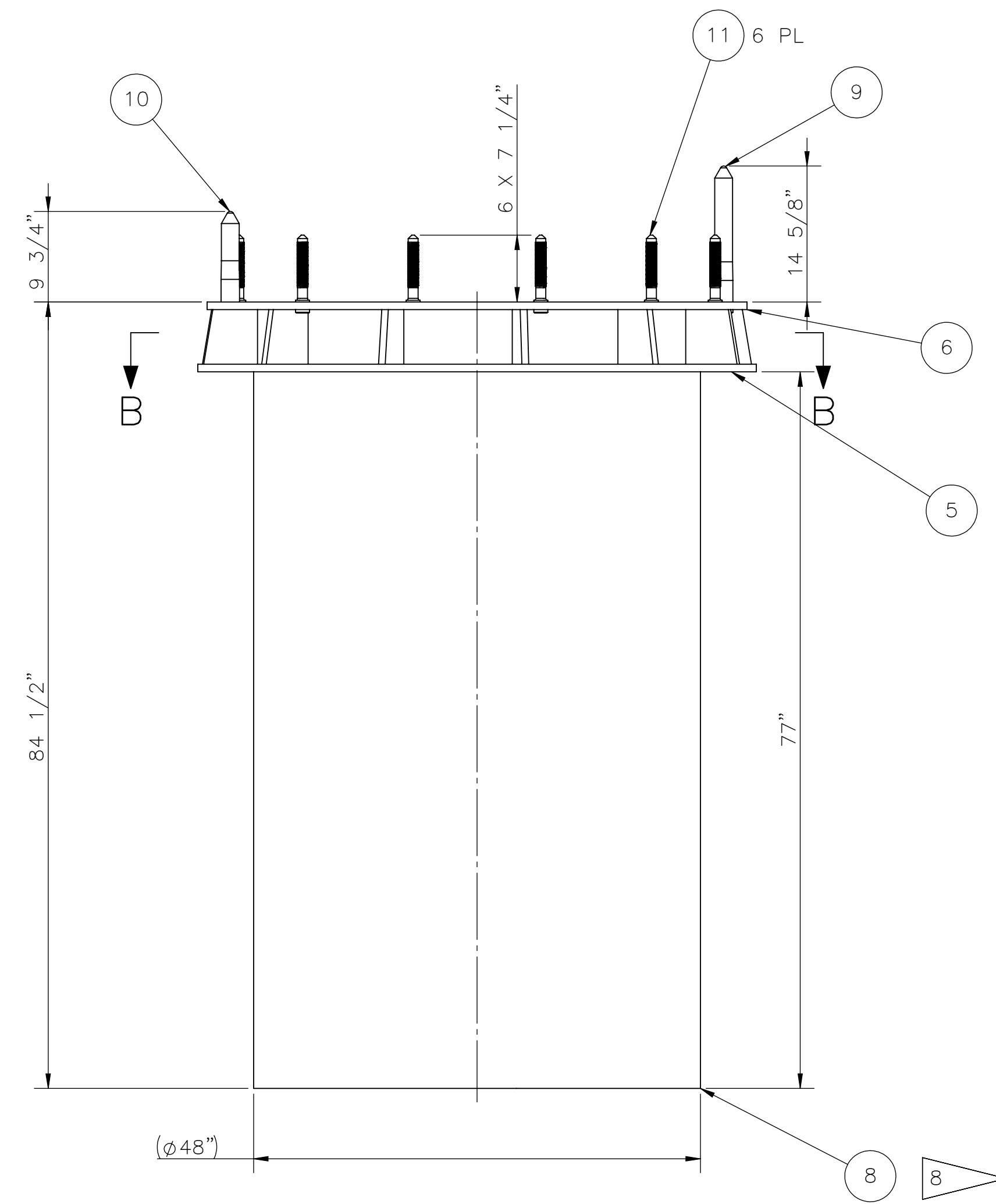

1 PWST 48 INCH RISER ASSEMBLY
SCALE: 1"=1'-0"
PART DETAILS ON SHT 3

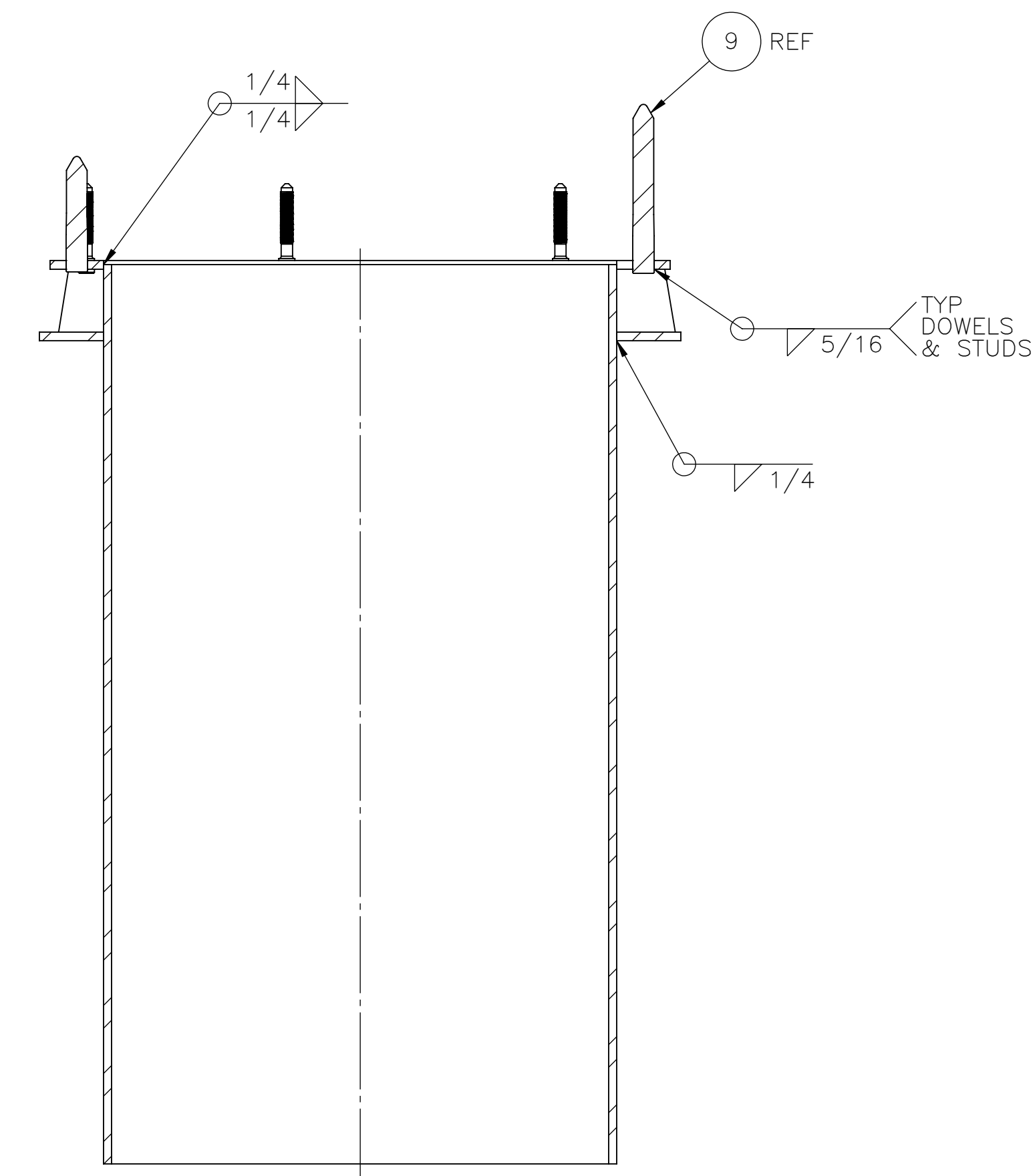

SECTION A-A
SCALE: 1"=1'-0"

PRELIMINARY
NOT FOR CONSTRUCTION

DWG NUMBER	TITLE	REF NUMBER	TITLE	REV NO	DESCRIPTION
		H-17-121300	DRAWING INDEX	B	RELEASED PER EDT-TBD
DRAWING TRACEABILITY LIST			REFERENCES		
NEXT USED ON			REVISIONS		

BLDG NO		CAUTION: NOT COMPLETE WITHOUT CURRENT CHANGE DOCUMENTS FROM DATABASE	
241-SY-304	NAME	DATE	COMPANY
	STERMER		U.S. DEPARTMENT OF ENERGY
	DRAFTING CHECKER		Hanford Field Office
			MECHANICAL
			SY PWST RISER ASSEMBLIES
			48 IN RISER ASS'Y
INDEX NO	SIZE	DRAWING NUMBER	SHEET
	F	H-14-113517	2
			B
			SCALE: SHOWN
			PLOTID
			1

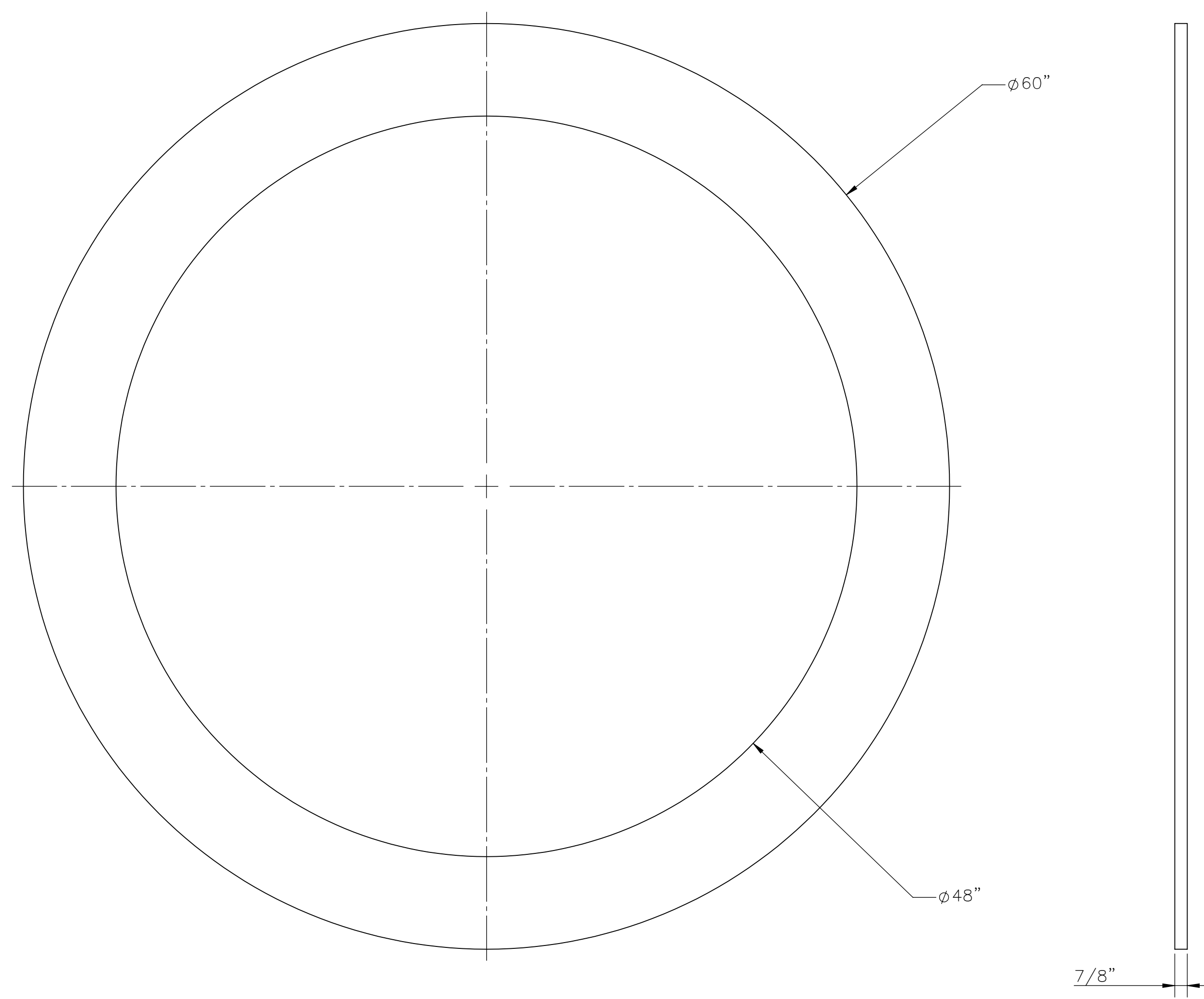

⑤ 48 INCH RISER BOTTOM PLATE
SCALE: 2"=1'-0"

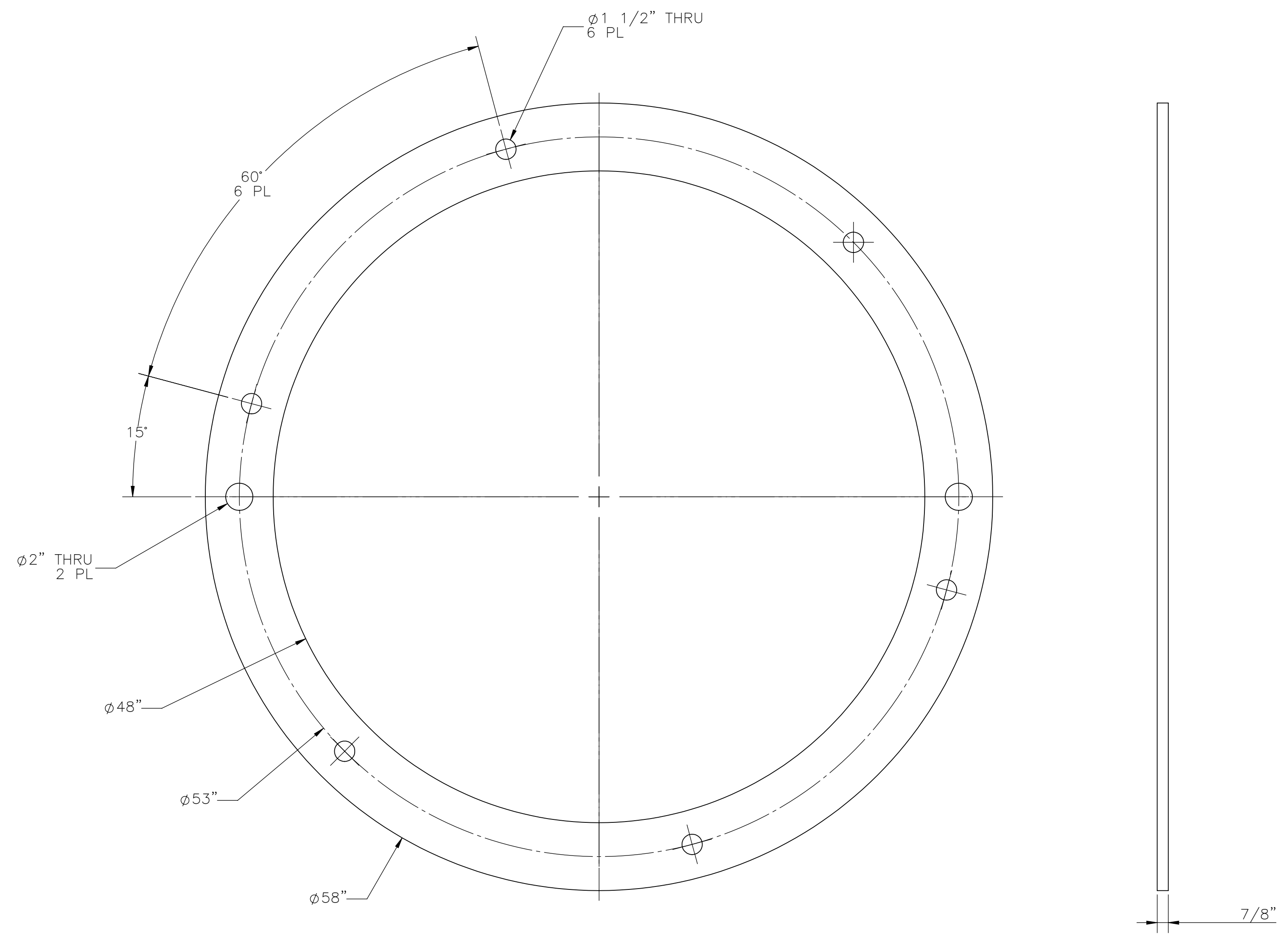

⑥ 48 INCH RISER TOP PLATE
SCALE: 2"=1'-0"

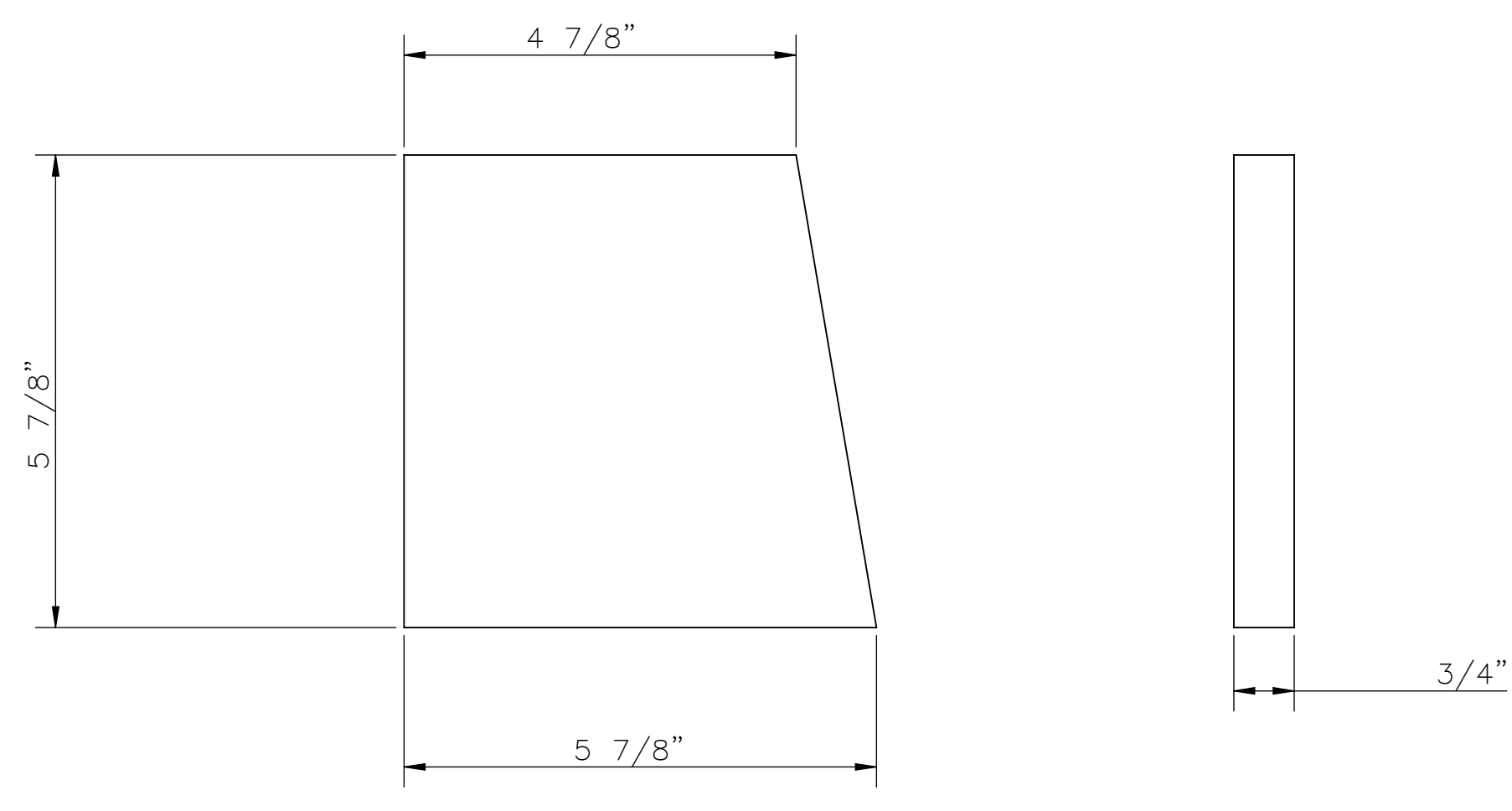

⑦ 48 INCH RISER GUSSET PLATE
SCALE: 6"=1'-0"

NOTES:
1. SEE SHEET 1 FOR GENERAL NOTES.

PRELIMINARY
NOT FOR CONSTRUCTION

BLDG NO 241-SY-304		CAUTION: NOT COMPLETE WITHOUT CURRENT CHANGE DOCUMENTS FROM DATABASE	
DRAWN BY STERMER	NAME	DATE	COMPANY U.S. DEPARTMENT OF ENERGY Hanford Field Office
DRAFTING CHECKER	HDC	HDC	
DESIGN AUTHORITY	HDC	HDC	
INDEX NO	SIZE F	DRAWING NUMBER H-14-113517	SHEET 3
	HDC	SCALE: SHOWN	REV B

DWG NUMBER	TITLE	REF NUMBER	TITLE	REV NO	DESCRIPTION
	DRAWING TRACEABILITY LIST		REFERENCES		REVISIONS

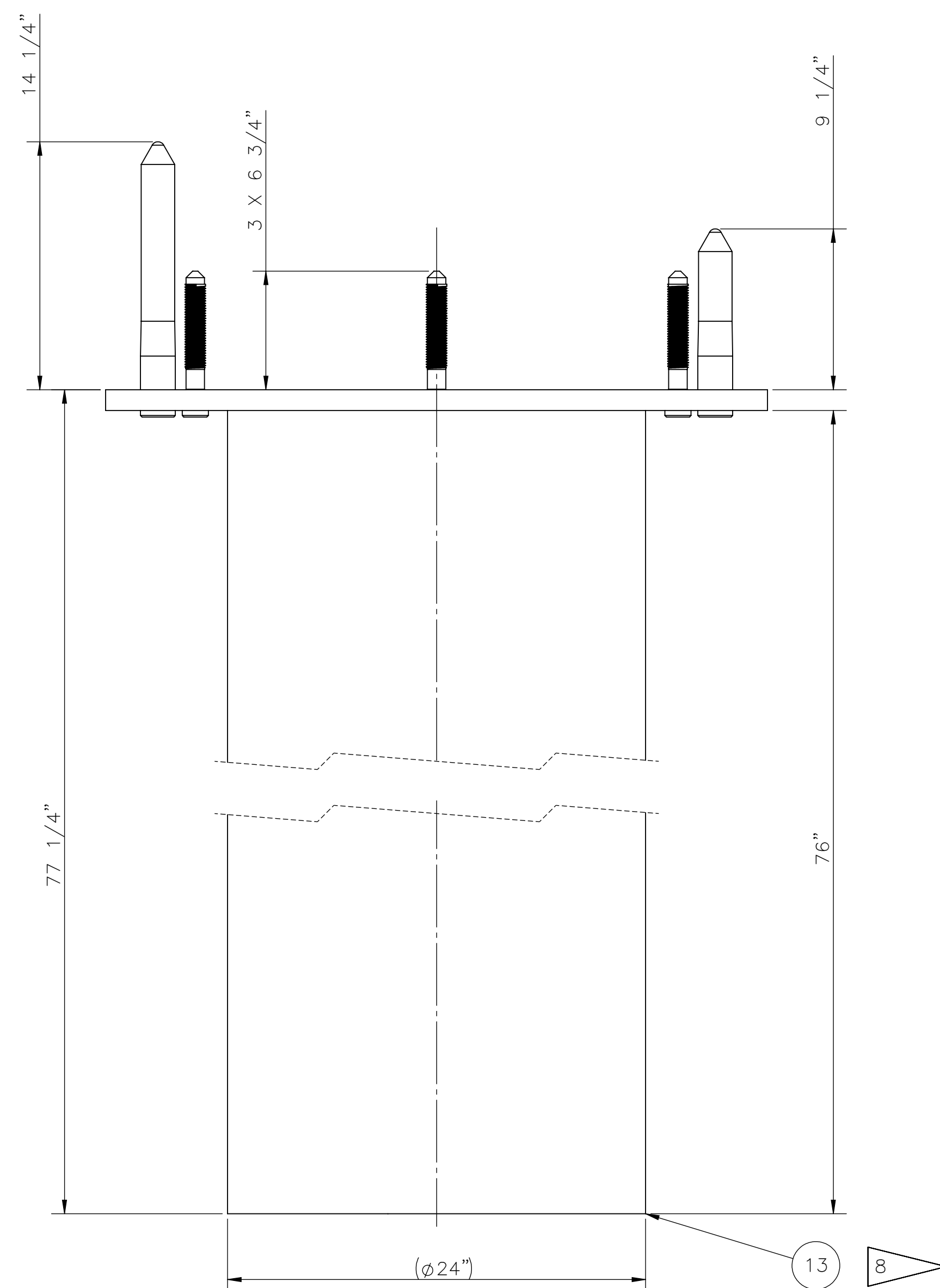
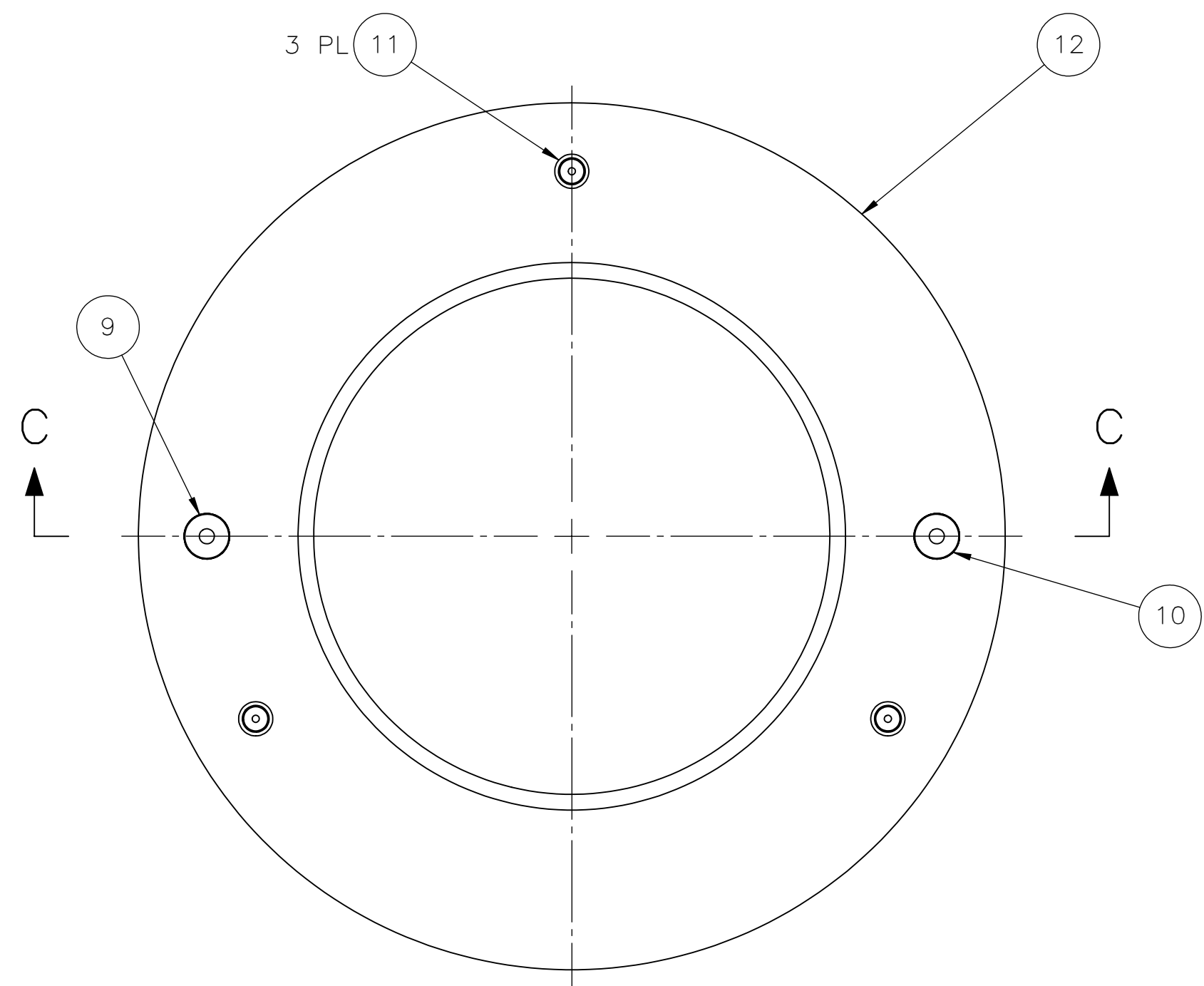

② PWST 24 INCH RISER ASSEMBLY
SCALE: 2"=1'-0"

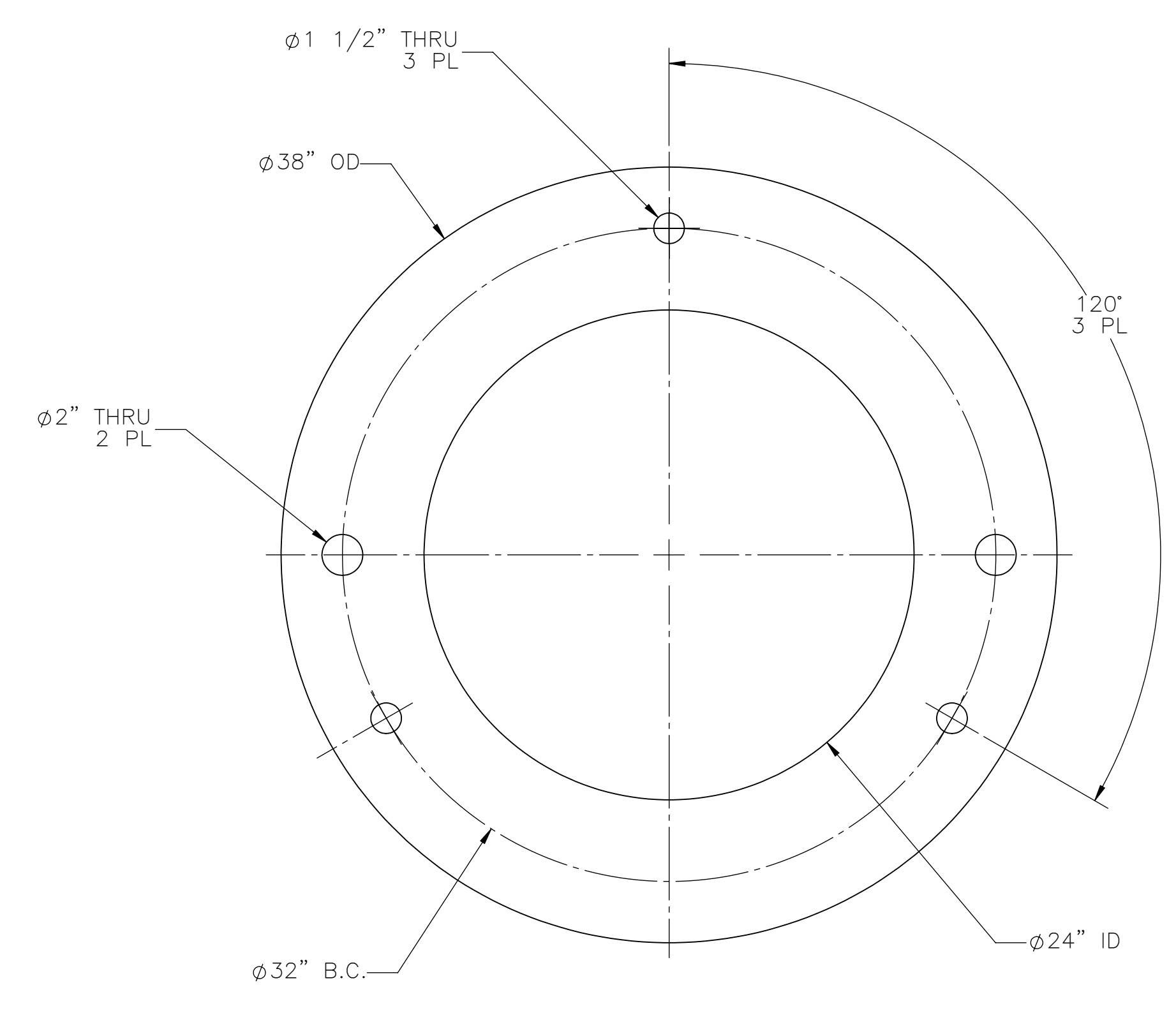

⑫ 24 INCH RISER PLATE
SCALE: 2"=1'-0"

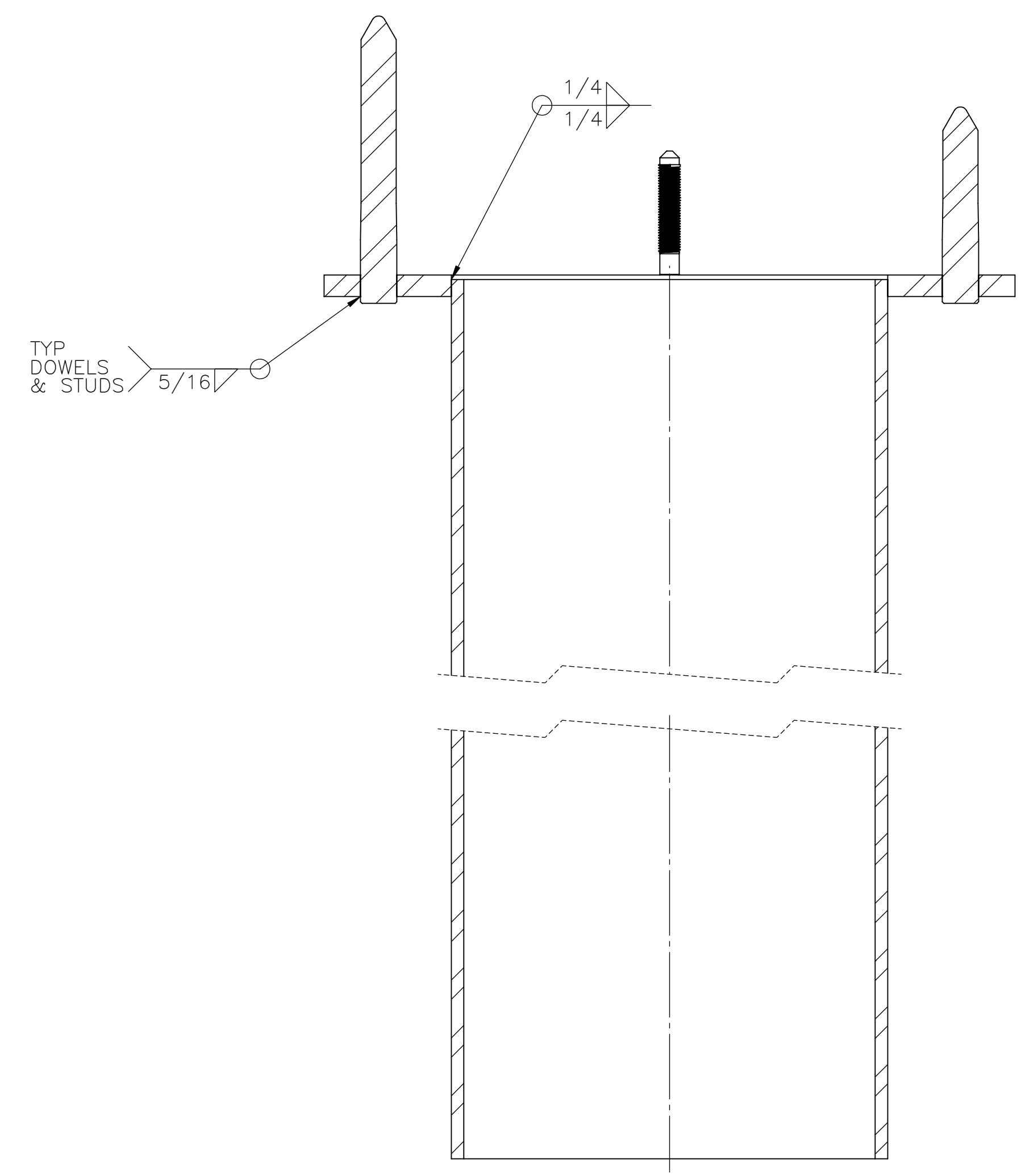

SECTION C-C
SCALE: 2"=1'-0"

NOTES:
1. SEE SHEET 1 FOR GENERAL NOTES.

PRELIMINARY
NOT FOR CONSTRUCTION

DWG NUMBER	TITLE	REF NUMBER	TITLE	REV NO	DESCRIPTION
	DRAWING TRACEABILITY LIST		REFERENCES		REVISIONS

BLDG NO 241-SY-304	CAUTION: NOT COMPLETE WITHOUT CURRENT CHANGE DOCUMENTS FROM DATABASE		DATE	COMPANY
DRAFTER J. STERMER	NAME	U.S. DEPARTMENT OF ENERGY		
DRAFTING CHECKER		Hanford Field Office		
		MECHANICAL		
		SY PWST RISER ASSEMBLIES		
		24 IN RISER ASS'Y		
INDEX NO	SIZE F	DRAWING NUMBER H-14-113517	SHEET 4	REV B
DESIGN AUTHORITY	HSE	SCALE: SHOWN		

B RELEASED PER EDT-TBD

